



# Product Specification

G150XVN01.1

AU OPTRONICS CORPORATION

(V) Preliminary Specification  
( ) Final Specification

<b>Module</b>	15" XGA TFT-LCD Module
<b>Model Name</b>	G150XVN01.1

<b>Customer</b>	<b>Date</b>
_____	_____
<b>Approved by</b>	
_____	_____
<p>Note: This Specification is subject to change without notice.</p>	

<b>Checked &amp; Approved by</b>	<b>Date</b>
Crystal Hsieh	12/10/2014
<b>Prepared by</b>	<b>Date</b>
Wennie Lee	12/10/2014
<p>Audio-Video Display Business Unit / AU Optronics corporation</p>	



**Contents**

**1. Handling Precautions..... 4**

**2. General Description..... 5**

    2.1 Display Characteristics..... 5

    2.2 Optical Characteristics ..... 6

**3. Functional Block Diagram..... 9**

**4. Absolute Maximum Ratings.....10**

    4.1 TFT LCD Module ..... 10

    4.2 Absolute Ratings of Environment ..... 10

**5. Electrical characteristics.....11**

    5.1 TFT LCD Module ..... 11

**6. Signal Characteristic .....14**

    6.1 Pixel Format Image ..... 14

    6.2 The Input Data Format ..... 15

    6.3 Signal Description..... 16

    6.4 Interface Timing ..... 17

    6.5 Power ON/OFF Sequence ..... 19

**7. Connector & Pin Assignment .....20**

    7.1 Connector..... 20

    7.2 Pin Assignmtne ..... 20

**8. Reliability Test .....21**

**9. Shipping Label.....22**

**10. Packing Form.....22**

    10.1 Packaging material ..... 22

    10.2 Packing instruction..... 22

    10.3 Palletizing ..... 23

**11. Outline Drawing .....24**



## Record of Revision

Version & Date	Page	Old Description	New Description	Remark
0.0 2013/12/10	All	Frist Draft		
0.1 2014/11/21	5		Update Power Consumption, Weight and Physical Size	
	6		Update 2.2 Optical Characteristics	
	8		Update Note 4	
	10		Delete Note 4 graph	
	11		Update 5.1.1 Power Specification	
	13		Update 5.1.3 Backlight Unit	
	16		Update 6.3 Signal Description	
	17		Update Note1	
	18		Update 6.4.1 Timing Characteristics	
	19		Update 6.5 Power ON/OFF Sequence	
	20		Update 7.1 Connector	
	22		Update 9. Label and 10. Packing	
	23		Update 10.3 Palletizing	
	24		Update 11. Outline Drawing	
0.2 2014/12/10	20	Mating Housing Part Number: HRS MDF76KBW or MDF76LBRW	Mating Plug Part Number: HRS MDF76-30P-1C	



## 1. Handling Precautions

- 1) Since front polarizer is easily damaged, please be cautious and not to scratch it.
- 2) Be sure to turn off power supply when inserting or disconnecting from input connector.
- 3) Wipe off water drop immediately. Long contact with water may cause discoloration or spots.
- 4) When the panel surface is soiled, wipe it with absorbent cotton or soft cloth.
- 5) Since the panel is made of glass, it may be broken or cracked if dropped or bumped on hard surface.
- 6) To avoid ESD (Electro Static Discharge) damage, be sure to ground yourself before handling TFT-LCD Module.
- 7) Do not open nor modify the module assembly.
- 8) Do not press the reflector sheet at the back of the module to any direction.
- 9) In case if a module has to be put back into the packing container slot after it was taken out from the container, do not press the center of the LED light bar edge. Instead, press at the far ends of the LED light bar edge softly. Otherwise the TFT Module may be damaged.
- 10) At the insertion or removal of the Signal Interface Connector, be sure not to rotate nor tilt the Interface Connector of the TFT Module.
- 11) TFT-LCD Module is not allowed to be twisted & bent even force is added on module in a very short time. Please design your display product well to avoid external force applying to module by end-user directly.
- 12) Small amount of materials without flammability grade are used in the TFT-LCD module. The TFT-LCD module should be supplied by power complied with requirements of Limited Power Source (IEC60950-1 or UL60950-1), or be applied exemption.
- 13) Severe temperature condition may result in different luminance, response time and lamp ignition voltage.
- 14) Continuous operating TFT-LCD display under low temperature environment may accelerate lamp exhaustion and reduce luminance dramatically.
- 15) The data on this specification sheet is applicable when LCD module is placed in landscape position.
- 16) Continuous displaying fixed pattern may induce image sticking. It's recommended to use screen saver or shuffle content periodically if fixed pattern is displayed on the screen.



## 2. General Description

G150XVN01.1 is a Color Active Matrix Liquid Crystal Display composed of a TFT-LCD panel, a driver circuit, and a backlight system. The screen format is intended to support the XGA (1024(H) x 768(V)) screen and 16.2M colors. All input signal is one channel LVDS interface.

### 2.1 Display Characteristics

The following items are characteristics summary on the table under 25 condition:

Items	Unit	Specifications
Screen Diagonal	[inch]	15.0"
Active Area	[mm]	304.128 (H) x 228.096 (V)
Pixels H x V		1024 x 768
Pixel Pitch	[mm]	0.297 (per one triad) x 0.297
Pixel Arrangement		R.G.B. Vertical Stripe
Display Mode		VA, Normally Black
White Luminance	[cd/m <sup>2</sup> ]	300 (center, Typ)
Contrast Ratio		1500 : 1 (Typ)
Optical ResponseTime	[msec]	35 (Typ, on/off)
Nominal Input Voltage VDD	[Volt]	+3.3
Power Consumption	[Watt]	10.1W (Typ)
Weight	[Grams]	910(Typ)
Physical Size (H x V x D)	[mm]	326.5 (H) x 253.5 (V) x 9.6 (D) (Typ)
Electrical Interface		one channel LVDS
Surface Treatment		Hard-coating (3H), Anti-Glare treatment
Support Color		16.2M / 262K colors
Temperature Range Operating Storage (Non-Operating)	[°C] [°C]	-10 to +70 (Tgs) -30 to +70 (Ta)
RoHS Compliance		RoHS Compliance



## 2.2 Optical Characteristics

The optical characteristics are measured under stable conditions at 25 (Room Temperature).

Item	Unit	Conditions	Min.	Typ.	Max.	Note
Viewing Angle	[degree]	Horizontal (Right) CR = 10 (Left)	70 70	85 85	-	1
		Vertical (Up) CR = 10 (Down)	70 70	85 85	-	
Contrast Ratio		Normal Direction	700	1500	-	
Optical Response Time	[msec]	Raising Time (TrR)	-	20	-	2
		Falling Time (TrF)	-	15	-	
		Rising + Falling	-	35	-	
Color / Chromaticity Coordinates (CIE)		Red x	0.589	0.639	0.689	
		Red y	0.295	0.345	0.395	
		Green x	0.276	0.326	0.376	
		Green y	0.571	0.621	0.671	
		Blue x	0.102	0.152	0.202	
		Blue y	0.008	0.058	0.108	
		White x	0.250	0.300	0.350	
		White y	0.275	0.325	0.375	
Central Luminance	[cd/m <sup>2</sup> ]		240	300	-	3
Luminance Uniformity	[%]	5 Points	75	-	-	4,5
NTSC	%		-	72	-	

Optical Equipment: BM-5A, BM-7, PR880, or equivalent

**Note 1: Definition of viewing angle**

Viewing angle is the measurement of contrast ratio 10, or 5, at the screen center, over a 180° horizontal and 180° vertical range (off-normal viewing angles). The 180° viewing angle range is broken down as follows; 90° ( ) horizontal left and right and 90° ( ) vertical, high (up) and low (down). The measurement direction is typically perpendicular to the display surface with the screen rotated about its center to develop the desired measurement viewing angle.

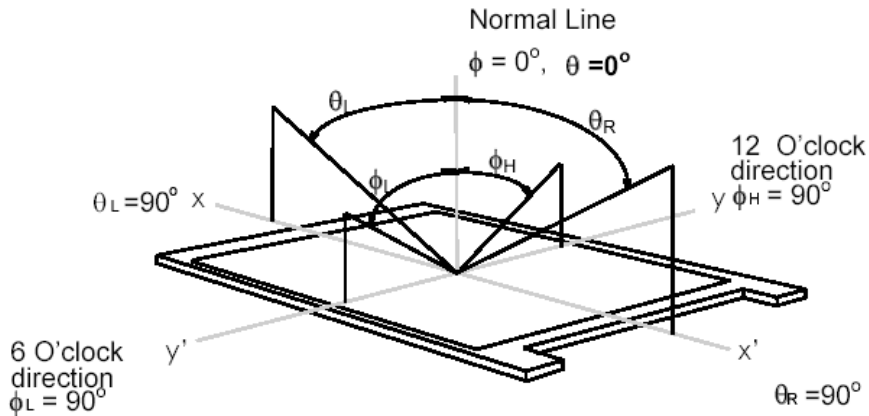

**Note 2: Definition of response time:**

The output signals of photo detector are measured when the input signals are changed from “Full Black” to “Full White” (rising time), and from “Full White” to “Full Black” (falling time), respectively. The response time is interval between the 10% and 90% of amplitudes. Please refer to the figure as below.

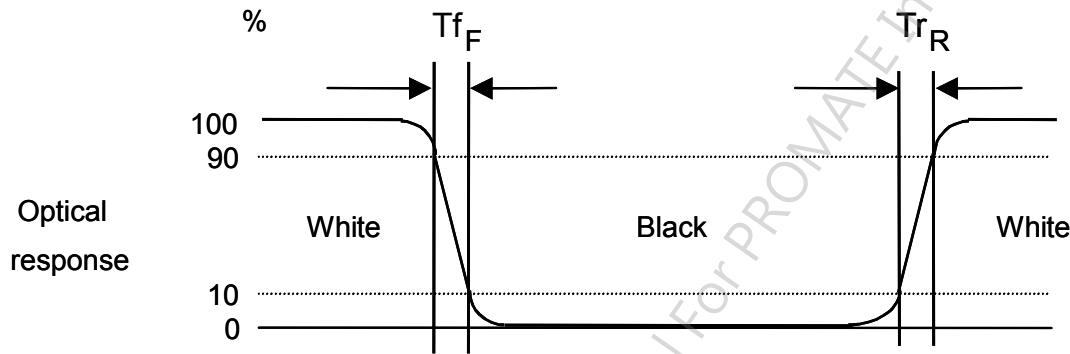

Note 3: Measurement method

The LCD module should be stabilized at given temperature for 30 minutes to avoid abrupt temperature change during measuring. In order to stabilize the luminance, the measurement should be executed after lighting Backlight for 30 minutes in a stable, windless and dark room.

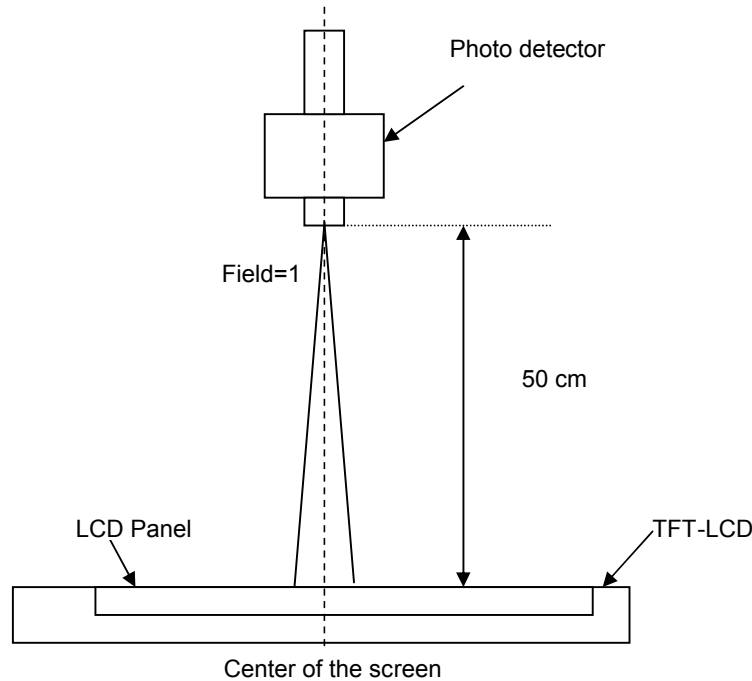

Note 4: 5 points position

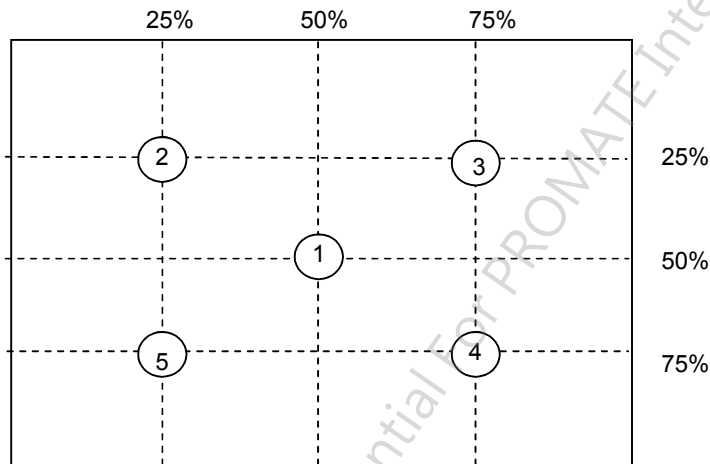

Note 5:

$$\text{Uniformity} = \frac{\text{Minimum Luminance in 5 points (1 - 5)}}{\text{Maximum Luminance in 5 Points (1 - 5)}}$$



## 3. Functional Block Diagram

The following diagram shows the functional block of the 15.0 inches wide Color TFT-LCD Module:

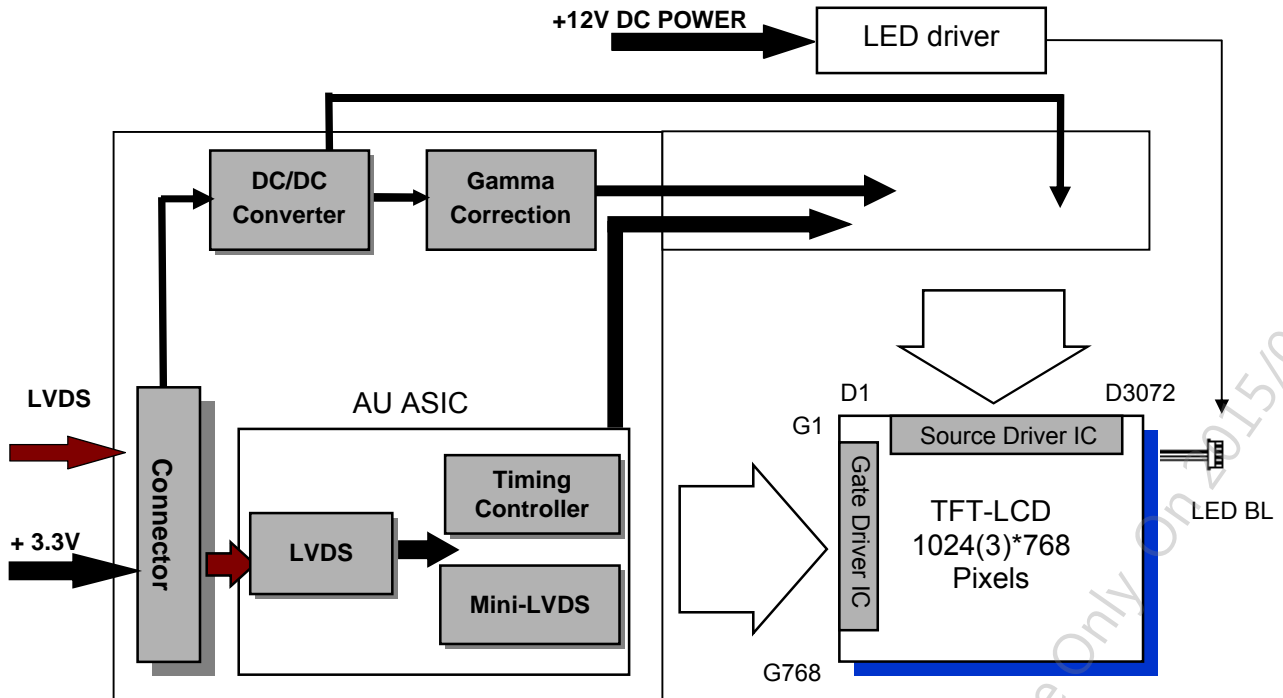



### 4. Absolute Maximum Ratings

Absolute maximum ratings of the module are as following:

#### 4.1 TFT LCD Module

Item	Symbol	Min	Max	Unit	Conditions
Logic/LCD Drive Voltage	VDD	-0.3	+4.0	[Volt]	Note 1,2

#### 4.2 Absolute Ratings of Environment

Item	Symbol	Min.	Max.	Unit	Conditions
Operating Temperature (Tgs)	TOP	-10	+70	[°C]	Note 3
Operation Humidity	HOP	5	95	[%RH]	Note 3
Storage Temperature (Ta)	TST	-30	+70	[°C]	
Storage Humidity	HST	5	95	[%RH]	

Note 1: With in Ta (25 )

Note 2: Permanent damage to the device may occur if exceeding maximum values

Note 3: Temperature and relative humidity range are shown as the below figure.

1. 95% RH Max ( Ta 39 )
2. Max wet-bulb temperature at 39 or less. ( Ta 39 )
3. No condensation

Note 4: Function Judged only

AUO Confidential For PROMATE Internal Use Only On 2015/01/09



## 5.1.2 Signal Electrical Characteristics

Input signals shall be low or Hi-Z state when VDD is off.

Each signal characteristics are as follows;

Symbol	Parameter	Min	Typ	Max	Units	Condition
$V_{TH}$	Differential Input High Threshold	-	-	+100	[mV]	$V_{CM} = 1.2V$ Note 1
$V_{TL}$	Differential Input Low Threshold	-100	-	-	[mV]	$V_{CM} = 1.2V$ Note 1
$V_{ID}$	Input Differential Voltage	100	400	600	[mV]	Note 1
$V_{CM}$	Differential Input Common Mode Voltage	+1.1	-	+1.45	[V]	$V_{TH}-V_{TL} = 200mV$ (max) Note 1

Note1: LVDS Signal Waveform

### Single-end Signal

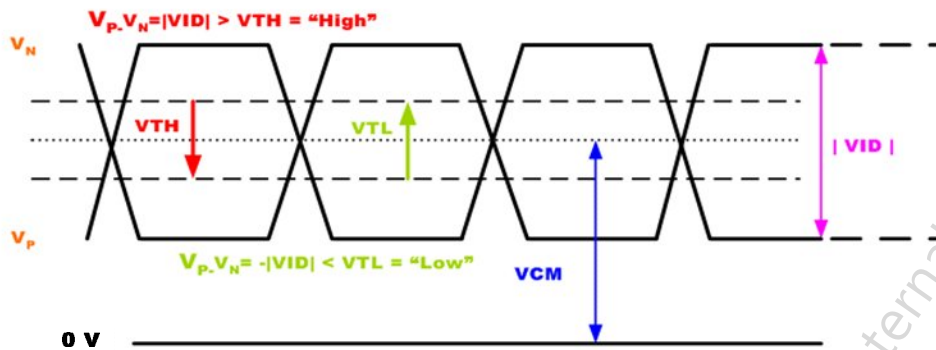

### Differential Signal

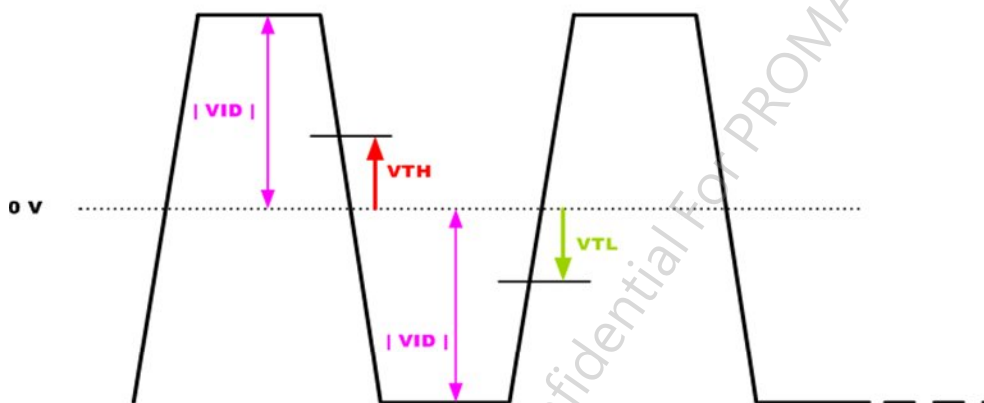

## 5.1.3 Backlight unit

Parameter guideline for LED driving is under stable conditions at 25 (Room Temperature):

Symbol	Parameter	Min.	Typ.	Max.	Unit	Remark
VCC	Input Voltage	10.8	12	13.2	[Volt]	
ICC	Input Current	-	0.65	0.9	[A]	100% PWM Duty
PCC	Power Consumption	-	7.8	12	[Watt]	100% PWM Duty
F <sub>PWM</sub>	Dimming Frequency	200	-	20K	[Hz]	
	Swing Voltage	3	3.3	5	[Volt]	
	Dimming duty cycle	5	-	100	%	
I <sub>F</sub>	LED Forward Current	-	60	-	[mA]	Ta = 25°C
V <sub>F</sub>	LED Forward Voltage	-	-	-	[Volt]	I <sub>F</sub> = 100mA, Ta = 0°C
		-	3.2	3.96	[Volt]	I <sub>F</sub> = 100mA, Ta = 25°C
		-	-	-	[Volt]	I <sub>F</sub> = 100mA, Ta = 70°C
P <sub>LED</sub>	LED Power Consumption	-	6.91	8.55	[Watt]	I <sub>F</sub> = 100mA, Ta = 25°C
LED Life Time		-	30,000	-	Hrs	I <sub>F</sub> = 100mA, Ta = 25°C

Note 1: Ta means ambient temperature of TFT-LCD module.

Note 2: VCC, ICC, PCC are defined for LED backlight.(100% duty of PWM dimming)

Note 3: I<sub>F</sub>, V<sub>F</sub> are defined for one channel LED. There are three LED channel in back light unit.

Note 4: If G150XVN01.1 module is driven by high current or at high ambient temperature & humidity condition. The operating life will be reduced.

Note 5: Operating life means brightness goes down to 50% initial brightness. Minimum operating life time is estimated data.

Note 6: LED lifetime is definition: brightness is decreased to 50% of the initial value. LED lifetime is restricted under normal condition, ambient temperature = 25 and LED operating IF = 100mA.

## 6. Signal Characteristic

### 6.1 Pixel Format Image

Following figure shows the relationship of the input signals and LCD pixel format.

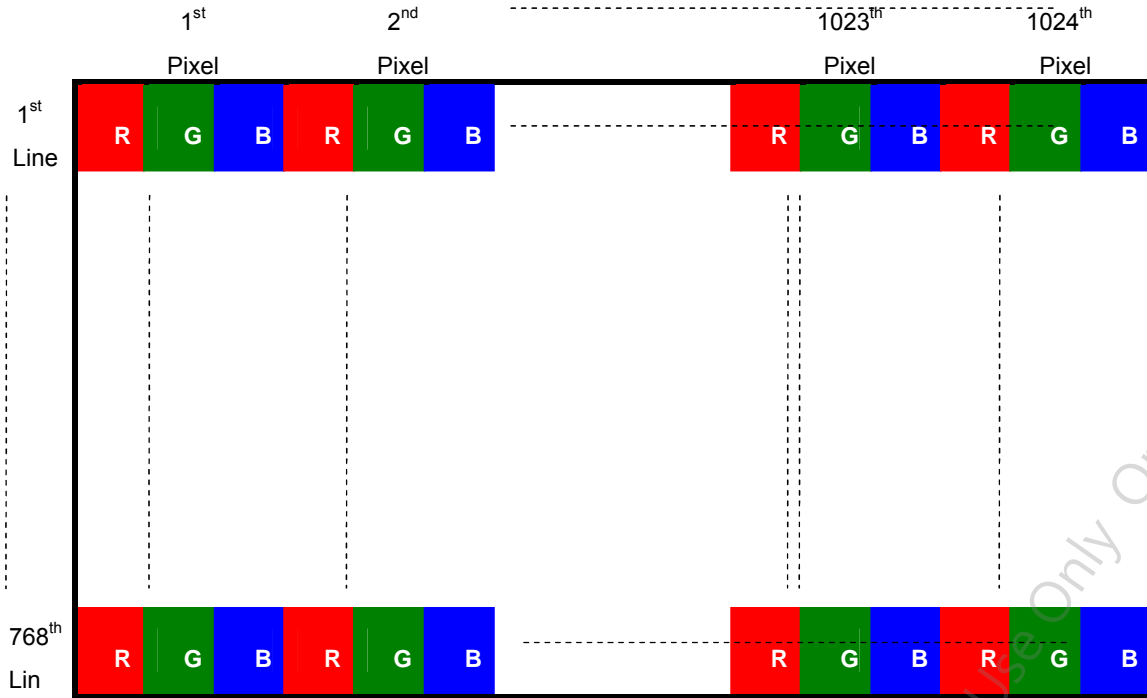

## 6.2 The Input Data Format

SEL LVDS = "H" for 6 bits LVDS Input

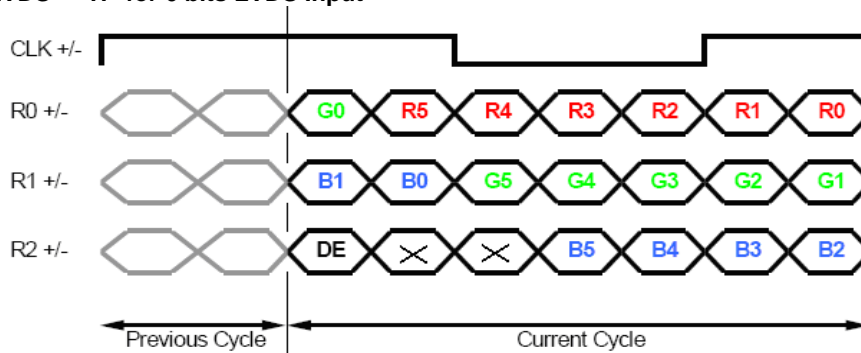

SEL LVDS = "L" or NC for 8 bits LVDS Input

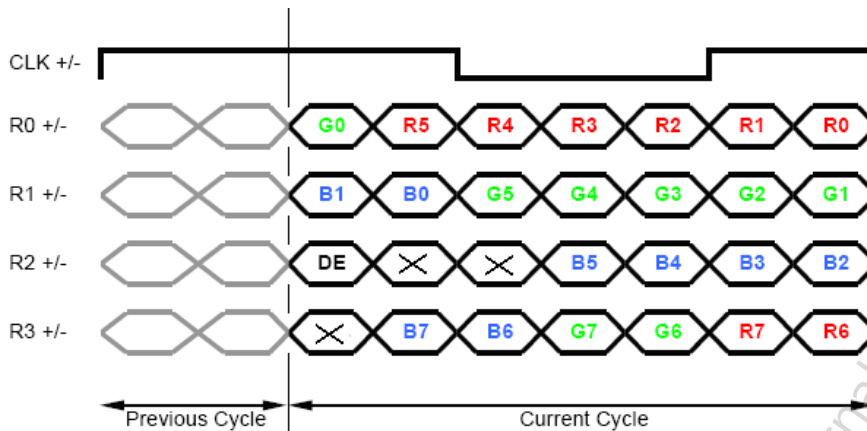

Note1: Please follow PSWG.

Note2: R/G/B data 7:MSB, R/G/B data 0:LSB

## 6.3 Signal Description

The module using one LVDS receiver SN75LVDS82(Texas Instruments). LVDS is a differential signal technology for LCD interface and high speed data transfer device. LVDS transmitters shall be SN75LVDS83(negative edge sampling). The first LVDS port(RxOxxx) transmits odd pixels while the second LVDS port(RxExxx) transmits even pixels.

MDF76TW-30S-1H (HIROSE)		
Pin No.	Symbol	Description
1	GND	Ground
2	GND	Ground
3	VCC	LED BL Power Supply, 12V
4	VCC	LED BL Power Supply, 12V
5	GND	Ground
6	On/Off	LED BL On/Off (3.3-5V:On, 0V:Off)
7	PWM	LED BL PWM dimming
8	GND	Ground
9	VDD	LCD Power Supply, 3.3V
10	VDD	LCD Power Supply, 3.3V
11	GND	Ground
12	GND	Ground
13	Rin0-	- LVDS differential data input (R0-R5, G0)
14	Rin0+	+ LVDS differential data input (R0-R5, G0)
15	GND	Ground
16	Rin1-	- LVDS differential data input (G1-G5, B0-B1)
17	Rin1+	+ LVDS differential data input (G1-G5, B0-B1)
18	GND	Ground
19	Rin2-	- LVDS differential data input (B2-B5, HS, VS, DE)
20	Rin2+	+ LVDS differential data input (B2-B5, HS, VS, DE)
21	GND	Ground
22	ClkIN-	- LVDS differential clock input
23	ClkIN+	+ LVDS differential clock input
24	GND	Ground
25	Rin3-	- LVDS differential data input (R6-R7, G6-G7,B6-B7)
26	Rin3+	+ LVDS differential data input (R6-R7, G6-G7,B6-B7)
27	GND	Ground
28	RL/UD	H: 180 degree rotation/ L: Normal mode
29	SEL LVDS	L : 8 bit / H : 6bit
30	GND	Ground (Note 1)



Note1: Start from left side

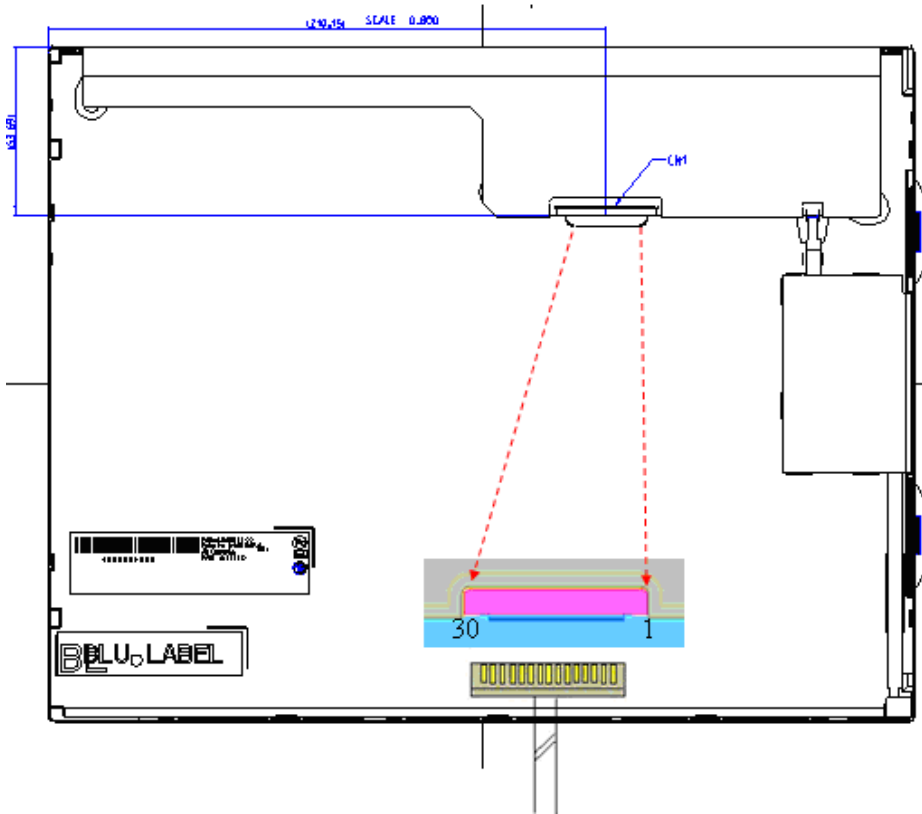

AUO Confidential For PROMATE Internal Use Only On 2015/01/09

## 6.4 Interface Timing

### 6.4.1 Timing Characteristics

Signal	Item	Symbol	Min	Typ	Max	Unit
Vertical Section	Period	$T_v$	776	806	990	Th
	Active	$T_{disp(v)}$	-	768	-	Th
	Blanking	$T_{bp(v)}+T_{fp(v)}+PW_{vs}$	8	38	222	Th
Horizontal Section	Period	$T_h$	1094	1344	1720	Tclk
	Active	$T_{disp(h)}$	-	1024	-	Tclk
	Blanking	$T_{bp(h)}+T_{fp(h)}+PW_{hs}$	70	320	696	Tclk
Clock	Frequency	Freq.	50	65	80	MHz
Frame Rate	Frequency	$1/T_v$	50	60	75	Hz

Note: DE mode only

Note: Typical value refer to VESA STANDARD

### 6.4.2 Timing Diagram

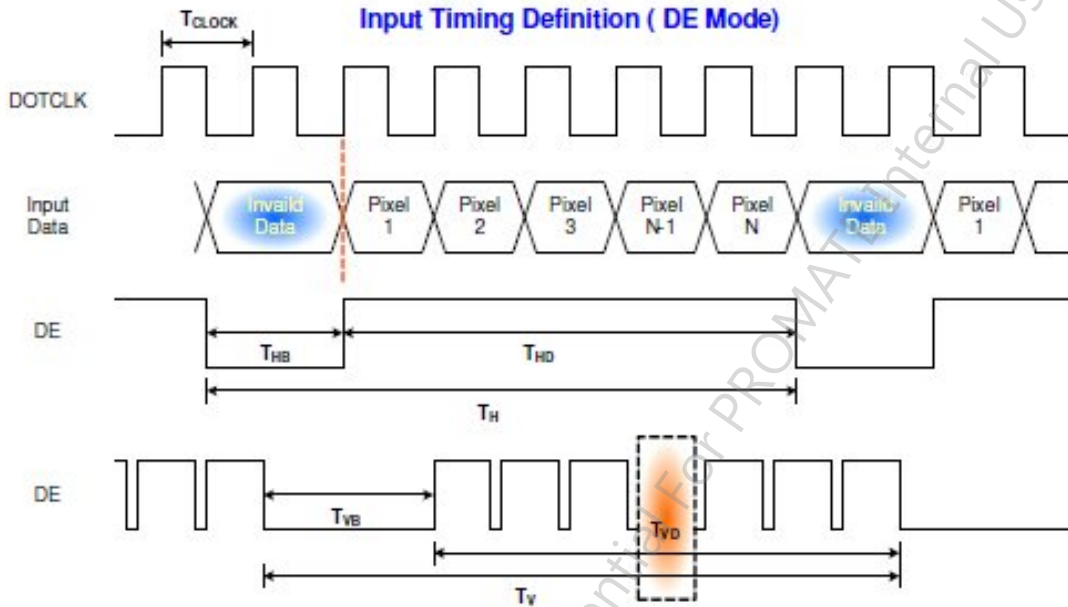

## 6.5 Power ON/OFF Sequence

VDD power and lamp on/off sequence are as follows. Interface signals are also shown in the chart. Signals from any system shall be Hi-Z state or low level when VDD is off.

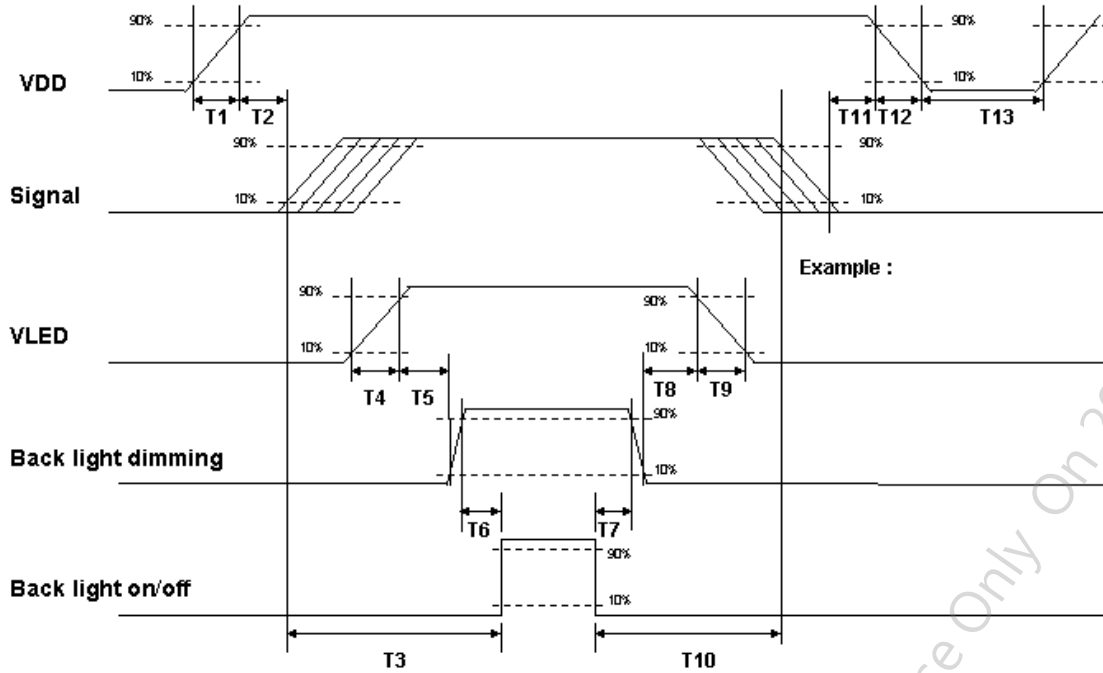

Parameter	Value			Unit
	Min.	Typ.	Max.	
T1	0.5	-	10	[ms]
T2	30	40	50	[ms]
T3	220	-	-	[ms]
T4	0.5	-	10	[ms]
T5	10	-	-	[ms]
T6	10	-	-	[ms]
T7	0	-	-	[ms]
T8	10	-	-	[ms]
T9	-	-	10	[ms]
T10	110	-	-	[ms]
T11	0	16	50	[ms]
T12	-	-	10	[ms]
T13	1000	-	-	[ms]



## 7. Connector & Pin Assignment

Physical interface is described as for the connector on module. These connectors are capable of accommodating the following signals and will be following components.

### 7.1 Connector

Connector Name / Designation	Interface Connector / Interface card
Manufacturer	HIROSE
Type Part Number	HRS MDF76TW-30S-1H
Mating Plug Part Number	HRS MDF76-30P-1C

### 7.2 Pin Assignment

Pin#	Signal Name	Pin#	Signal Name
1	GND	16	Rin1-
2	GND	17	Rin1+
3	VCC	18	GND
4	VCC	19	Rin2-
5	GND	20	Rin2+
6	On/Off	21	GND
7	PWM	22	ClkIN-
8	GND	23	ClkIN+
9	VDD	24	GND
10	VDD	25	Rin3-
11	GND	26	Rin3+
12	GND	27	GND
13	Rin0-	28	RL/UD
14	Rin0+	29	SEL LVDS
15	GND	30	GND

## 8. Reliability Test

Environment test conditions are listed as following table.

No.	Test items	Conditions	Remark
1	High temperature storage	Ta= 70                      240Hrs	
2	Low temperature storage	Ta= -30                      240Hrs	
3	High temperature operation	Tgs= 70                      240Hrs	
4	Low temperature operation	Ta= -10                      240Hrs	
5	High temperature and high humidity	Ta= 40 , 95% RH              240Hrs	
6	Thermal shock	-30 /30min, 70 /30min, 50 cycles	
7	Vibration	Acceleration: 1.5 G Wave: Random Frequency: 10 - 200 - 10 Hz Sweep: 30 Minutes each Axis (X, Y, Z)	
8	Mechanical shock	Acceleration: 50 G Wave: Half-sine Active Time: 20 ms Direction: ±X, ±Y, ±Z (one time for each Axis)	
9	Vibration (with carton)	Random vibration: 0.015G <sup>2</sup> /Hz from 5~200Hz -6dB/octave from 200~500Hz	
10	Electro Static discharge (ESD)	Contact Discharge: ±8KV, 150pF(330Ω ) 1sec, 8 points, 25 times/ point.  Air Discharge: ± 15KV, 150pF(330Ω ) 1sec, 8 points, 25 times/ point.	Note 1

Note1: According to EN61000-4-2, ESD class B: Some performance degradation allowed. No data lost  
Self-recoverable. No hardware failures.

Note2:

- Water condensation is not allowed for each test items.
- Each test is done by new TFT-LCD module. Don't use the same TFT-LCD module repeatedly for reliability test.
- The reliability test is performed only to examine the TFT-LCD module capability.
- To inspect TFT-LCD module after reliability test, please store it at room temperature and room humidity for 24 hours at least in advance.
- No function failure occurs.

## 9. Shipping Label

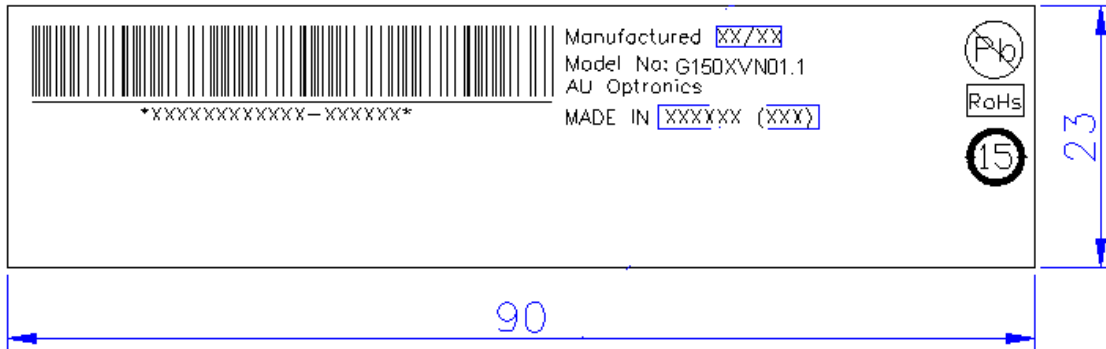

## 10. Packing Form

### 10.1 Packaging material

FILM PROTECT
BAG ANTI-STATIC
TAPE
TAPE CREPED PAPER
PACKING CARTON
LABEL SPEC
LABEL CARTON.
CUSHION PACKING

### 10.2 Packing instruction

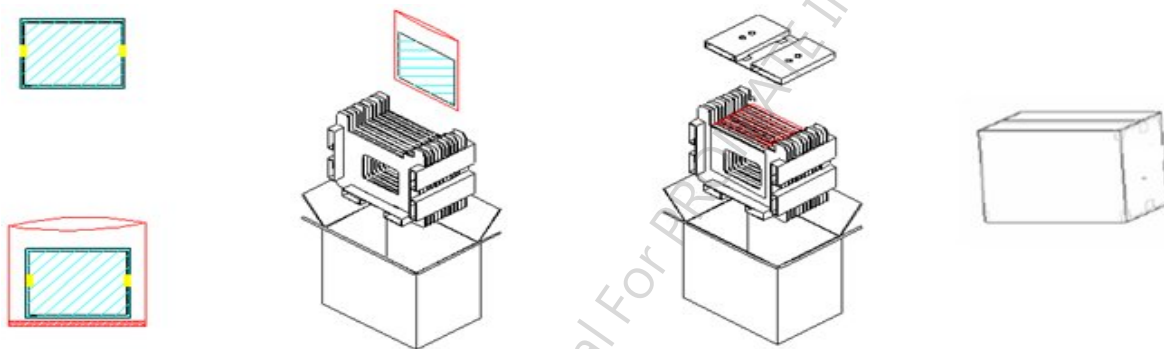

Max capacity : 10 TFT-LCD module per carton

Max weight: 12.5 kg per carton

Outside dimension of carton: 410mm(L)\* 278mm(W)\*360mm(H)

Pallet size : 1140 mm \* 830 mm \* 135mm

## 10.3 Palletizing

Module by air\_Max : (2 \*4) \*4 layers , one pallet put 32 boxes , total 320pcs module

Module by sea\_Max : (2 \*4) \*4 layers + (2 \*4) \*1 layers , two pallet put 40 boxes , total 400pcs module

Module by sea\_HQ\_Max : (2 \*4) \*4 layers+(2 \*4) \*2 layers, two pallet put 48 boxes, total 480pcs module

	MAX SHIPPING BY AIR	MAX SHIPPING BY SEA	MAX SHIPPING BY SEA_HQ
MODULE/CARTON	10	10	10
CARTON/LAYER	8	8	8
LAYER/PALLET	4	4+1	4+2
MODULE/PALLET	320	400	480
CARTON_SIZE(MM)	410(L)*278(W)*360(H)	410(L)*278(W)*360(H)	410(L)*278(W)*360(H)
PALLET_SIZE(MM)	1140(L)*830(W)*138(H)	1140(L)*830(W)*138(H)	1140(L)*830(W)*138(H)
TOTAL PALLET HEIGHT(MM)	1575	2070	2430
TOTAL PALLET WEIGHT(KG)	413	526	626

ONE PALLET SHIPMENT EXAMPLE SHIPPING BY AIR USED

TWO PALLETS SHIPMENT EXAMPLE SHIPPING BY SEA USED

TWO PALLETS SHIPMENT EXAMPLE SHIPPING BY SEA\_HQ USED



# Product Specification

AU OPTRONICS CORPORATION

G150XVN01.1

## 11. Outline Drawing

